

FAMU-FSU College of Engineering

Midterm Report

SAR Imager

Team #18

EML 4551C

Instructors: Dr. Nikhil Gupta and Dr. Chiang Shih
Sponsor: Michael Blue
Faculty Advisor: Dr. Dorr Campbell

*Submitted:
October 26, 2015*

<i>Members:</i>	<i>ID:</i>
<i>Luke Baldwin</i>	<i>kn11e</i>
<i>Josh Dennis</i>	<i>jad11d</i>
<i>Kaylen Nollie</i>	<i>lrb11e</i>
<i>Desmond Pressey</i>	<i>drp14d</i>



NORTHROP GRUMMAN



Table of Contents

Table of Figures	iv
Table of Tables	v
ABSTRACT	vi
ACKNOWLEDGMENTS	vii
1. Introduction	1
2. Background	2
2.1 Northrop Grumman	2
2.2 SAR Overview	3
2.3 First Generation.....	6
3. Project Definition	8
3.1 Need Statement	8
3.2 Goal Statement & Objectives.....	8
3.3 Constraints.....	10
3.3.1 Stability	10
3.3.2 Weight and Mobility.....	11
3.3.3 Horns.....	11
3.3.4 Cost	11
4. Concept Generation and Overview	12
4.1 Structure Designs	12
4.1.1 Design S-1: 80/20 Structure.....	12
4.1.2 Design S-2: Custom Aluminum Structure	14
4.2 Horn Holder Designs.....	15
4.2.1 Design H-1: Bracket Enclosure	15

4.2.2	Design H-2: Articulating Arm	16
4.3	Base Designs	18
4.3.1	Design B-1: 80/20 Castors	18
4.3.2	Design B-2: Pre-Fabricated Cart.....	19
5.	Concept Selection	20
5.1	Structure Selection	20
5.2	Horn Holder Analysis and Selection.....	21
5.2.1	Design H-1 Analysis.....	21
5.2.2	Design H-2 Analysis.....	22
5.2.3	Horn Design Selection	22
5.3	Base Selection	23
6.	Methodology	24
6.1	Work Breakdown Structure.....	24
6.2	Schedule	25
6.3	Resource Allocation	26
7.	Risk Assessment	27
8.	Future Plans	28
8.1	General Overview	28
8.2	Upcoming Deadlines	28
9.	Conclusion	29
	References.....	30
	Appendix.....	31
	Biography.....	33

Table of Figures

Figure 1: Northrop Grumman B-2 Spirit Bomber (2).....	2
Figure 2: Mobile SARS (5).....	4
Figure 3: Antenna Array Creating Image (8).....	5
Figure 4: First Generation Project and Team, Faculty (9)	6
Figure 5: First Generation Final Budget (9)	7
Figure 6: Design S-1, 3D	13
Figure 7: Design S-2, 3D	14
Figure 8: Design H-1, 3D and Dimensioned Drawings	16
Figure 9: Design H-2, 3D and Detailed Drawings.....	17
Figure 10: Design B-1, 80/20 Leveling Castors (#2714).....	18
Figure 11: Design B-2, Aluminum Platform Truck (10)	19
Figure 12: Gantt Chart for Fall Semester.....	25

Table of Tables

Table 1: House of Quality.....	10
Table 2: Decision Matrix, Structure Design Selection	21
Table 3: Decision Matrix, Horn Holder Designs	23
Table 4: Work Breakdown Structure	24
Table 5: Risk Analysis	27
Table 6: Remaining Fall Schedule.....	28

ABSTRACT

Synthetic Aperture Radar is an advance technique of measuring a high resolution radar signature with a smaller antenna. The purpose of this project is to use SAR technology to create a low-resolution image for homeland security applications. Our product will be able to scan individuals for metal objects in order to designate people who need additional security screening. From contact with our sponsor, Northrop Grumman, our team has developed a concise problem statement: “Design an improved housing structure for the SAR Radar array.” This project is a continuation from last year’s senior design group. New objectives for this year include lowering the weight, making the structure more stable, fixing the antenna horn mounting and alignment, and reducing cost. At this point in the project, the team is nearing completion of the design phase, and is looking to finalize designs based on sponsor feedback.

ACKNOWLEDGMENTS

Mechanical Engineering Team 18 would like to thank Dr. Gupta and Dr. Shih of the FAMU-FSU College of Engineering for dedicating the time required to make the senior design program such an important learning tool for so many students.

Thanks also goes out to corporate sponsor Northrop Grumman for providing the funds to make this project possible, and to Pete Stenger and Michael Blue for taking the time to help our team through the learning process of project design and management.

1. Introduction

In partnership with the FAMU/FSU College of Engineering and Northrop Grumman, the objective of the Synthetic Aperture Radar (SAR) Imager Project is to develop a low-cost weapon detection system that provides suitable imagery resolution for physical security and military force protection applications.

Current detection technologies commonly employed in the security industry such as metal detectors, Advanced Imaging Technology (AIT) scanners, and x-ray scanners can be expensive, obtrusive, and require the subject to be inside the apparatus. An imager based on SAR technology, composed primarily of commercial-off-the-shelf (COTS) components, can be implemented at a lower cost than many industry-standard scanners; it may be placed behind a barrier, out of view from subjects; and most importantly, it can identify concealed metal objects from a distance.

In environments with multi-layered physical security protocols, the SAR imager's superior range can alert security professionals to potential threats before they reach an access control point, or before they progress further into a secure area, depending in which security layer the SAR is deployed. Some environments may be vulnerable to physical attack, but conventional AIT body scanners are too obtrusive or inefficient. An amusement park, for instance, might have high-level security needs, but their customers would not tolerate stepping into a full-body scanner.

Furthermore, random screening protocols have been widely criticized for being culturally or racially biased in practice. With SAR capability, guests can be discreetly imaged while queuing, and persons of interest can be identified for additional screening based on the presence of metal signatures rather than the caprice of a human screener.

This project is a continuation from last year. The first team to work on the project made major progress in pathfinding for this very unique, challenging project. While the work done by last year's team was an impressive feat for a first generation product, there are many things that can be improved upon this year. Two engineering teams are assigned to this project: one Electrical, and one Mechanical team. While the two groups work in tandem, this report will primarily consider the scope of the mechanical engineering team.

2. Background

2.1 Northrop Grumman

The fifth largest defense contracting company in the world, Northrop Grumman employs more than 68,000 people worldwide. In 2013, its reported revenue was \$24.6 billion. In 2011, the company was placed at number 72 on the Fortune 500 list of America's biggest corporations. Northrop Grumman has four business sectors: Aerospace Systems, Electronic Systems, Information Systems, and Technical Services (1).

Perhaps one of the most widely recognizable achievements by Northrop Grumman is the construction of the B-2 Spirit Bomber, as seen in Figure 1. Each one of these aircraft costs \$2 billion, and represents the pinnacle of high-tech, highly priced aircraft that makes the United States military such an unparalleled force worldwide.



Figure 1: Northrop Grumman B-2 Spirit Bomber (2)

Northrop Grumman has been the contractor for a number of recent high-budget projects. In 2013, a contract with the U.S. Air Force to develop a new aerial warfare training simulation network

was awarded, worth \$490 million. In 2014, Northrop Grumman “is the primary contractor for the James Webb Space Telescope,” a project worth an estimated \$8.7 billion (3). In 2015, the Pentagon announced that Northrop Grumman won a contract over a cooperative effort by Lockheed Martin and Boeing to develop the next long range bomber for the U.S. Air Force. The initial value of this contract is \$21.4 billion, and could yield nearly four times that throughout the life of the project (4).

2.2 SAR Overview

A Synthetic Aperture Radar System (SARS) is a radar system that generates a high resolution remote sensor imagery using multiple antennas and each antenna stores its’ data electronically (5). A SARS normally is used by the military in aircrafts and are used to find targets such as ships by taking Doppler’s Effect into account and having the antennas in time multiplex over a certain length (6). This means that the systems are usually used from the sky, looking downward toward the earth. Signal processing uses magnitude and phases of the received signals over successive pulses from elements of synthetic aperture and it then creates an image.

SARS are primarily used by mounting the system to an aircraft. Because the aircraft moves as it scans, this time-based displacement creates a synthetic length of a radar, giving it its name, as seen in Figure 2.

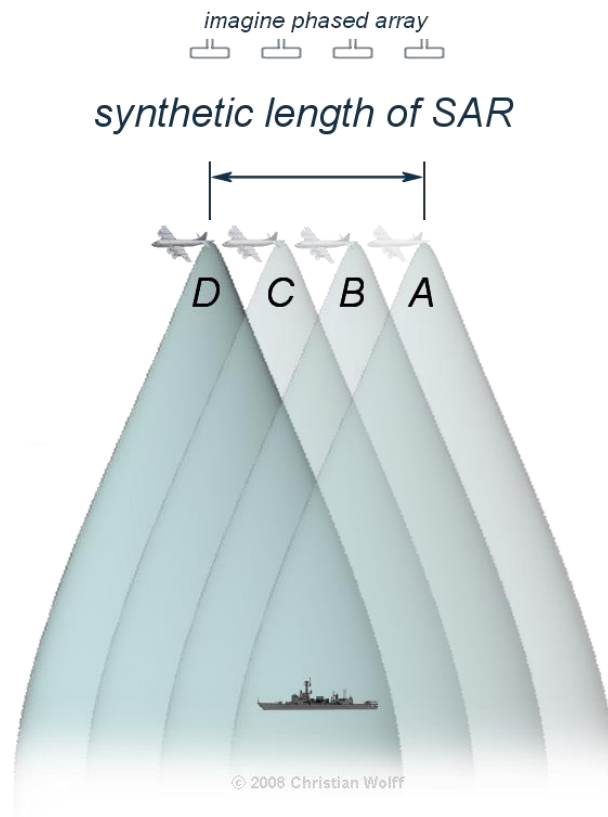

Figure 2: Mobile SARS (5)

SARS is used for military use primarily but there are also some non-military uses as well. The “Blackbird’s Eye” is where an aircraft pilot uses SARS to establish a location of an object. SARS is used for the 24/7 missions in hostile territories for reconnaissance and counter terrorism, this is specifically called the TRACER and are for unmanned and manned. This system can operate in any type of weather, day or night, wide area-surveillance capabilities, and has a long endurance. For non-military uses SARS is also used for GEO mapping, which is a mapping system to map areas all over the world. These three applications of the Synthetic Aperture Radar System were all created by Lockheed Martin and all are mobile (7).

Our objective is to make a SARS imager with a purpose of creating a strong security system to protect against threats in public places such as movie theaters and stadiums. People are able to conceal weapons such as handguns or even bombs in public areas without anyone having any knowledge that someone has a weapon and could be a potential perpetrator of mass murder or anything with malicious intent. The difference between a tradition SARS imager is that this

device will be on the ground with a target that is horizontal and also that the device will have multiple stationary antennas that is sending data to be stored electronically by taking images of a target that is moving, specifically a human being. Instead of using it in the air, this will be used on the ground and taking images horizontally. The imager should be fully functional, uses materials that are commercially used and low in cost, and also creates a low but useful resolution of an image that can detect concealed weapons.

Because this is a stationary SAR, multiple antennas must be used to create the synthetic length of the radar. There are 16 antennas that transmit radar, and 4 that receive – the 4 outermost antennas. The received signal will be passed to the electrical components for modification, and that data will be sent to a laptop for post-processing. The output will be low-resolution displaced of the 40x40 inch scene. This system is shown in Figure 3.

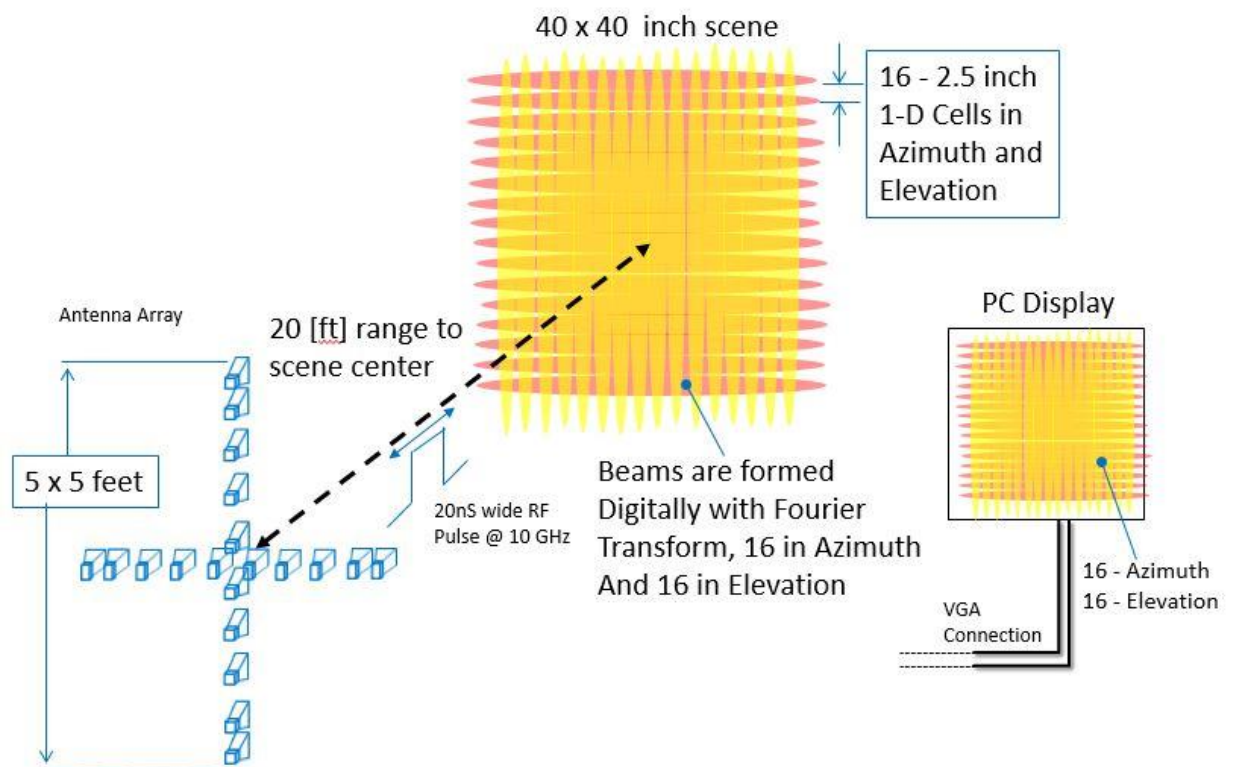

Figure 3: Antenna Array Creating Image (8)

2.3 First Generation

The dictating factor in the SAR design are the electrical engineering requirements. As such, the mechanical aspects of the project are there to supplement the electrical operation. Because of the unique and challenging nature of this project, the electrical engineers spent a considerable amount of time initially determining how to start with designing the layout of the system. This constrained the mechanical engineers by giving them less time to develop a prototype design. Once a final mechanical design was chosen for the system, the team proceeded by submitting the design package to various fabricating shops for quotation. The mechanical engineers chose the quote from a fabrication shop that was considerably cheaper than the average quote. Many of the problems of last year's design was introduced by the selected fabricator. These problems included not clearly understanding the design drawings and incorrectly fabricating parts which then must be re-fabricated, providing an estimated completion date that was not met, and subsequent lack of fabrication quality. The delays that were created in fabrication totaled three weeks. The poor fabrication quality also caused the horn holders to not fit onto the horn assembly properly, and the entire structure, as shown in Figure 4, is very unstable. Simply placing a hand on the side of the horizontal bar would cause the structure to wobble. This is detrimental to the operation of the SAR, causing a considerable amount of error to be introduced into the readings whenever it was bumped.



Figure 4: First Generation Project and Team, Faculty (9)

Additional constraints were placed on the mechanical engineers because throughout the life of the project, the electrical requirements consumed more and more of the budget. Although there was a significant amount of money not budgeted to be spent, most of that had to be spent on electrical components and renting test equipment. Because of budget, seen in Figure 5, a design that would have had the structure made out of aluminum had to be changed to steel. This cause the weight of the structure to increase so much that it was difficult to move, totaling over 220 pounds.

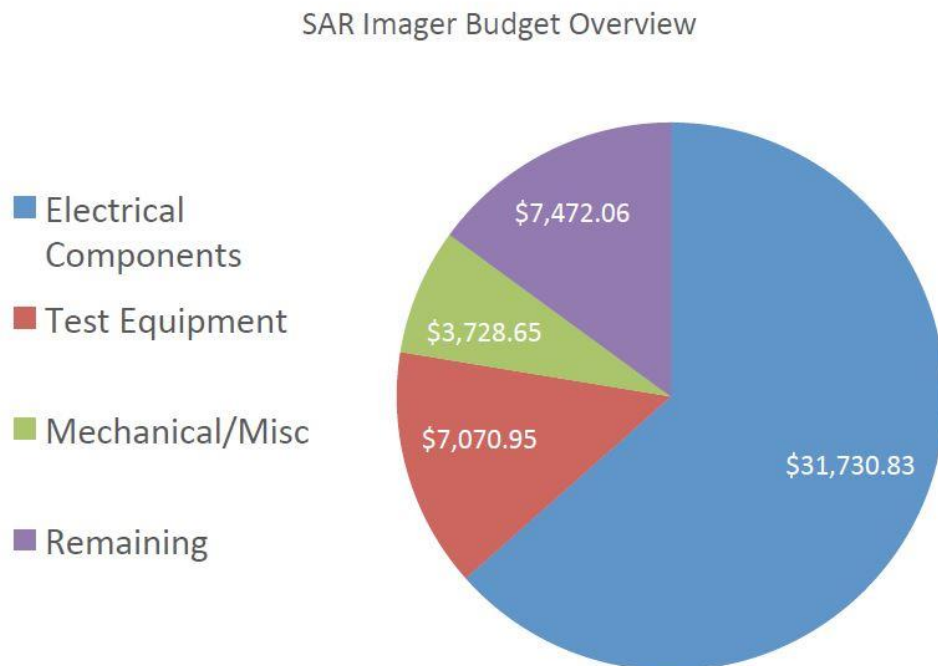

Figure 5: First Generation Final Budget (9)

3. Project Definition

Compared to other senior design projects, the SAR Imager is a project with open ended goals. It was difficult to initially get a clear idea of the direction of the project. The open nature is partially because it is difficult to assess what is achievable in nine months' time. Information regarding project definition has been outlined, but it is important to note that the scope can be changed as needed throughout the life of the project.

3.1 Need Statement

This is a second generation project; the sponsor being Northrop Grumman and the Mechanical Engineering team from the previous year has demanded some key changes in the aspects of the previous design. These include, improving the rigidity of the frame, changing the method of aligning the antenna horns, increasing mobility, reducing weight to under 150 lbs., changing the material of the structure, and increasing the pointing accuracy of the laser of the horn antenna. These changes are needed because, the horn alignment caused errors in the collection of data and target sensing. The changes are also needed because the current design was extremely too heavy and difficult to transport.

Need Statement:

“The structure of the current SARS is producing too much of an error and isn't efficient or effective for sensing targets.”

3.2 Goal Statement & Objectives

From our sponsor meeting, our team was able to create the following goal statement:

“Design an improved housing structure for the SAR Radar array.”

During our meeting, our sponsor stated very clearly what his concerns with last year's prototype and what we could do to make it better. The first requirement was improved stability, the 1st-Gen prototype would wobble upon the application of a small force. Operationally this is not acceptable because the SAR takes radar images of a fixed region in space and a small adjustment would mess up the accuracy of what is being read. Another element to help improve the accuracy is improved horn alignment and mounting. The first generation of the imager had a

problem with precisely mounting the horn holder to the frame and in some cases JB Weld was used hastily. It is important to finely adjust the angle of each antenna and lock it into place since errors of even $1/10^{\circ}$ can propagate to major errors in the phase angle of the radar signal.

Reducing the total weight is another major concern for Gen1 was made of solid steel and weighed roughly 300lbs. However, this was to save cost as lightweight Aluminum would have been more expensive. A goal of making it a Mil-Spec standard two person carry weight of 80lbs was given. Lowering the weight would also make the device more portable another of our client desires. However, portability can also include easy of breakdown and assembly which is not a main focus of our 2nd Gen design. Design of the hardware box to protect the circuitry from the elements and Electromagnet Interference was given to the two ME students on the EE team, however, we still need to make a way to attach their box to our structure.

From the design requirements, our team produced a House of Quality (HOQ) matrix as shown in Table 1. We took the design requirements provided by our client and ranked them in terms of importance. By brainstorming, our team created the engineering characteristics of structural thickness, specific material used, horn locking mechanism and adjustment, physical size of the base, height of the structure above ground, number of cross support beams and a Mil-Spec weight standard.

Table 1: House of Quality

Customer Requirements	Customer Importance	Engineering Characteristics								
		Structural Thickness	Material Used	Locking Mechanism	Axis Adjustability	Mounting Mechanism	Base size	Height Above Ground	Number of Crossbeams	Weight
Increased Stability	5	9	3	6		3	9	6	6	
Lower Weight	5	3	9				6	3	6	9
Good Images	5			6	9	9		3		
Better Horn Mounting	5			9	9	9				
Cost	4	3	6	3		3	3		3	
Hardware Box	2	3	6							3
Portability	2		6				9	6		9
Score		18	30	24	18	24	27	18	15	21
Relative Weight		78	108	117	90	117	105	72	72	69
Rank		6	3	1	5	1	4	7	7	9

Based on the HOQ, the most important engineering characteristics are the locking mechanism and mounting mechanism for the horns, followed by the material used in construction of the structure and the base size.

3.3 Constraints

Some engineering constraints have been proposed by Northrop Grumman. These are preliminary goals to aim for, but may need to be revised throughout the project since it is still a young, evolving product.

3.3.1 Stability

A main drawback of the first generation of the design was stability. A slight bump of the structure could cause significant wobbling, affecting the accuracy of the SAR. The stability is required because the radar being sent out and received by the antenna has a wavelength of 1 inch. Any movement of the structure will cause the received phase to be artificially shifted to the left

or the right. It was determined that the maximum allowable phase shift is 5 degrees. In terms of horizontal movement, this corresponds to $1/72$ of an inch in maximum deformation.

3.3.2 Weight and Mobility

The first generation product weighed over 220 pounds. Although this system is designed to be stationary, it is desirable that it can be both lifted and moved by two people, as well as having wheels so it is easy to move. Per military specifications, two people are generally considered to be able to lift an object of 80 pounds easily, so that will be the goal weight of the project. This weight goal may be revised as the project comes closer to actualization if needed.

3.3.3 Horns

The entire purpose of the structure is to facilitate the collection of data by the antenna horns. This will be the most critical design feature, so it will be given priority in design. The sponsor clearly outlined all requirements of the horn: the horns need to be adjustable through rotation in the left to right direction and through rotation in the up and down direction, all horns must be focused within a 1 foot circle that is 20 feet away, and there must be some method of alignment. Last year, the method of alignment was by using a mounted laser pointer to determine the alignment direction. A similar method will be considered this year.

3.3.4 Cost

Although the budget for the mechanical engineering aspects of the project is \$5000, the team's goal will be to find a satisfactory price to performance balance that will be below this amount. The methods to reduce cost will be to use commercial-off-the-shelf (COTS) hardware, and to keep design as simple as possible while still meeting engineering requirements.

4. Concept Generation and Overview

The various designs by the mechanical engineering team have already undergone multiple revisions through input by the sponsor and electrical team. The intention of this report is not to propose a final design, but to show the team's progress in the design process.

4.1 Structure Designs

The design of the structure is strictly dictated by the geometry of the antenna array. As long as the structure can support the 20 antenna horns and hardware box, the secondary goal of reducing weight and cost was pursued in design.

4.1.1 Design S-1: 80/20 Structure

The first design, Structure S-1, focuses around the use of 80-20, an industrial grade building structure and test platform as shown in Figure 6. 80-20 is very modular due to its extruded aluminum profile and can be combined to other pieces through a variety of connectors. This design is also very flexible because different sized pieces of 80-20 with different channel numbers can be selected if more strength or surface area is desired.

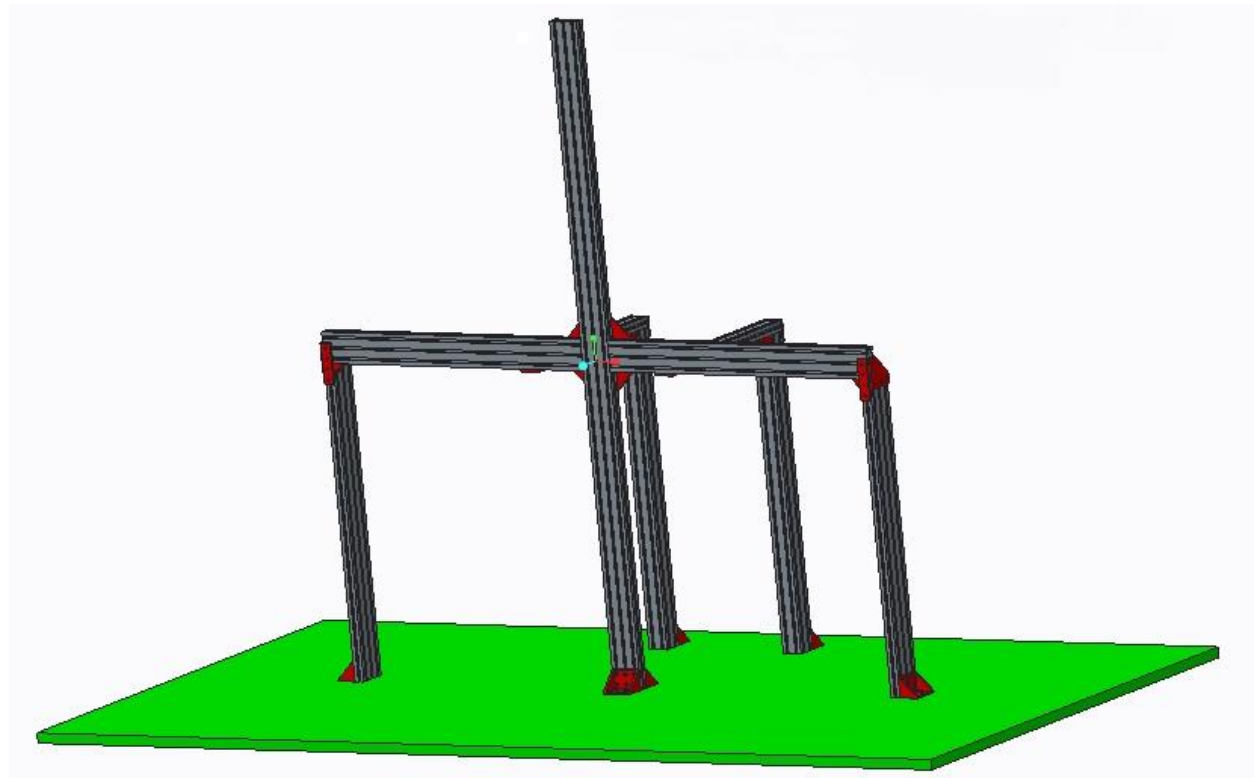

Figure 6: Design S-1, 3D

From the particular SAR radar array specified by Northrop Grumman, a 3x1 channeled piece of 80-20 was used as the main vertical and horizontal bars which hold the antennas in place. Four angled brackets are used on the back of the structure to provide rigidity to the structure. This allows for near endless translation of the waveguide holders so that they can be aligned relative to each other. 80-20's modular nature allows support beams to be attached anywhere. At the end of each horizontal beam, another 3x1 piece is used to support the far side. In order to keep the device from toppling forwards or backwards, two legs are added to each horizontal beam. This leg also serves to balance the weight of a central rear mounted control box if this location becomes specified by the EE team. The green base plate is an arbitrary ground; it shows how the structure would be mounted to a cart surface or floor with 45 angle brackets in red.

Rough dimensions of the Structure S-1 design are shown in **Error! Reference source not found.** below with all dimensions in inches. It stands 64" tall and 61" wide from the extreme ends of the cross beams. The top of the 3" wide arm is 33.5" above the ground making the center exactly at 32" above the ground. The rear leg stands 19" away from the front and connects to the very bottom channel of the horizontal arm at 31.5" high.

4.1.2 Design S-2: Custom Aluminum Structure

Design S-2 features influences from last year's design or Generation 1 (Gen1) and is shown below in Figure 7. Four pieces of Aluminum are bent or welded into an L shape and are attached together at their ends. The connectors at each horizontal end extend down to the floor to provide stability and weight relief to the center ground piece. Each waveguide adapter is sandwiched between two different pieces with a rectangular cutout placed in the proper distances for the antennas. There are four plastic gutters which protect and conceal the wires and are shown to be clear attached to the rear of the L beams.



Figure 7: Design S-2, 3D

Detailed drawings can be found in Appendix B.

Each L beam is made of 0.375" Aluminum and is spaced 4 inches apart from each other to offer clearance for the waveguide to rotate freely without interference. The rectangle which anchors the waveguide adapter and rotation mechanism are spaced 1.5" x 0.5" to all some adjustment room to fine tune their translation. This structure stands 64.55" tall and 63.65" wide with each arm 29" long. At the side of the structure, each end cap stands 35.85" tall and 29.075" away from the downward side of the center. The inside of each gutter is 4.75" apart and 26" long so

that it doesn't interfere with the end caps. The component box will be mounted to the back the horizontal sections of the L beams.

4.2 Horn Holder Designs

The most critical aspect of the mechanical engineering design of the project was the horn holders. The first generation design performed very poorly in this area, so the main improvement for the second generation is to improve on this aspect.

4.2.1 Design H-1: Bracket Enclosure

Design 1, as shown in Figure 8, will be mounted onto the 80-20 structure by the screw-to-clamp structure available from the 80-20 providers. This screw-to-clamp structure will be used on the back of the horn holding brackets. The outer rectangular brace of the structure will be fastened onto the braces by a thumb screw, rubber washer, and a nut. This outer brace will control the azimuth rotation of the horn. The outer brace is also connected to the flange by another set of thumb screws, rubber washers, and nuts. This rotational point controls the elevation of the horn. The flange is fastened onto the back of the waveguide along the same screws that connect the waveguide to the horn.

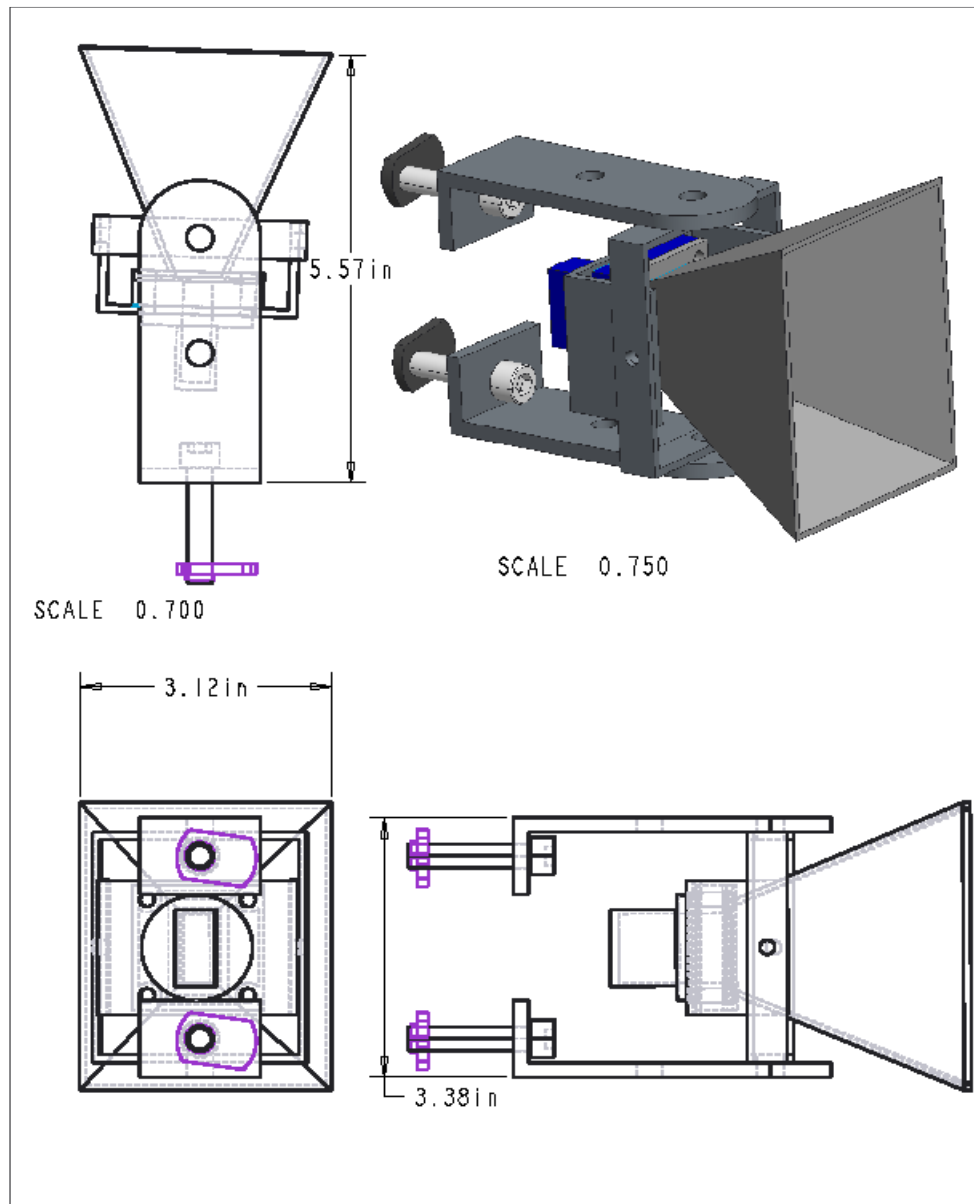

Figure 8: Design H-1, 3D and Dimensioned Drawings

4.2.2 Design H-2: Articulating Arm

Design 2, seen in Figure 9, copies that of a computer monitor; this is called an articulating arm. It is connected with three separate parts. There is a plate that is connected to a rod. This controls the rotation along the elevation and the rod rotates along the azimuth. The rod is then connected to the 80-20, 15 series, pivot nub that enables the design to connect to the 80-20 structure. In order for each degree of freedom to lock, disabling any adjustments in either the azimuth or elevation, depending which is trying to be adjusted, we have decided to use pins that will be able

to tighten or loosen the design so that it can be altered by the user. The pivot nub that slides into the structure will also be able to become fixed by the pins used by loosening and tightening.

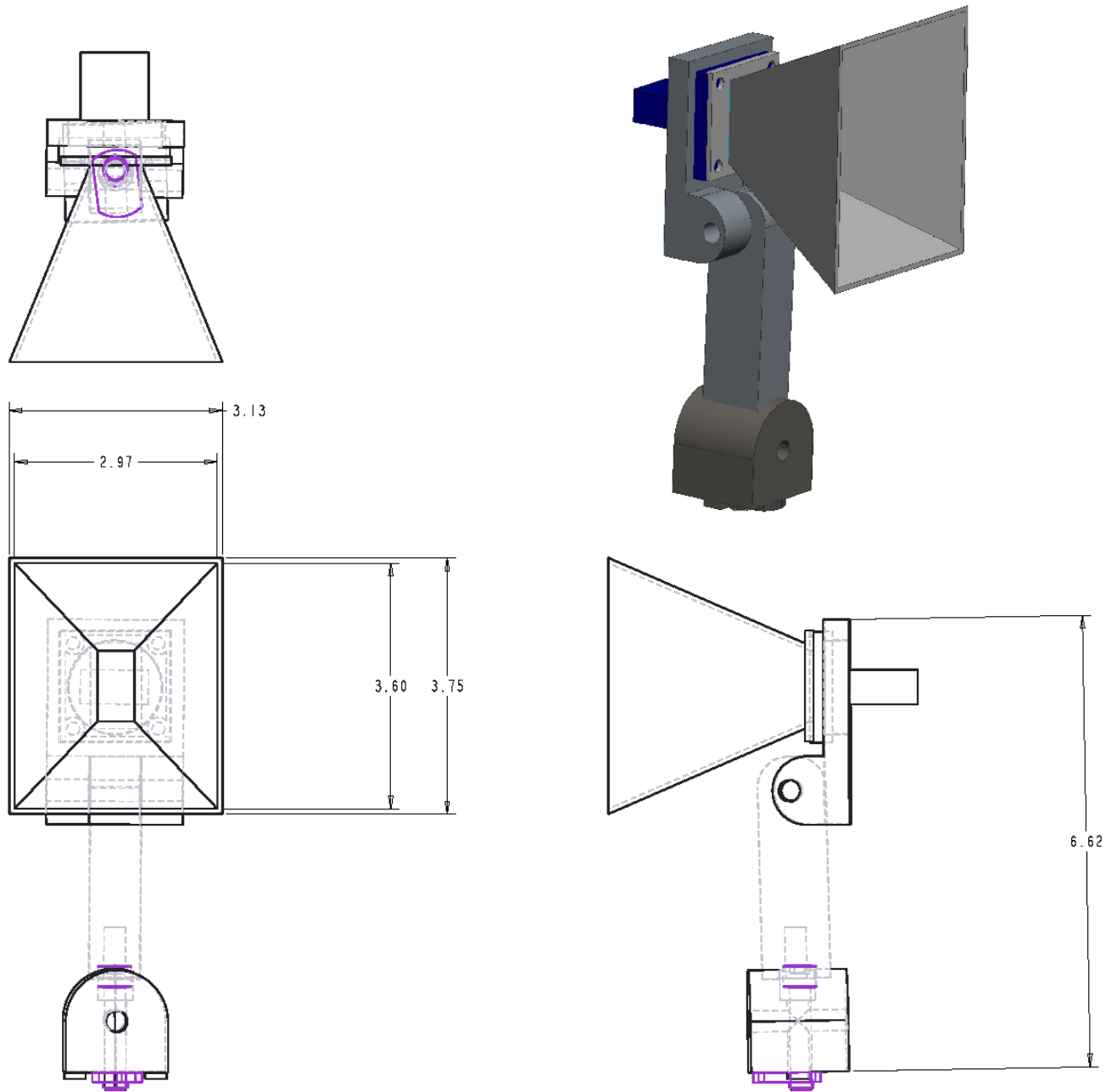

Figure 9: Design H-2, 3D and Detailed Drawings

4.3 Base Designs

The designs of the base are currently early in the design stages. Because both the horn holder and structure design are under heavy revision, the team is waiting on proposing detailed designs of the base. Although the team believes the design will be trivial to complete after the other aspects are finalized, there have been two proposed methods of constructing a base.

4.3.1 Design B-1: 80/20 Castors

The first base design is based off of structure design S-1 which uses the 80/20 product. The requirements of the operation of the SAR dictate that the system must be placed on a level floor. The mobility requirements of the project require that it have wheels to be easily moved. The team is considering a part that satisfies both of these requirements, seen in Figure 10.



© 80/20 Inc., All Rights Reserved

Figure 10: Design B-1, 80/20 Leveling Castors (#2714)

The general idea will be to create a rectangular frame on the bottom of the structure and attach four leveling castors.

4.3.2 Design B-2: Pre-Fabricated Cart

An additional idea proposed would be to purchase a pre-fabricated cart, and simply attach the structure to the cart. Many options are available from McMaster-Carr depending on the final geometry of the structure. One of these options is shown below.



Figure 11: Design B-2, Aluminum Platform Truck (10)

The advantage this design brings is that there will be little time required for assembly – possibly only installing a few bolts to mount the structure. There may be cost savings depending on the final cost of B-1. Less time will be spent on designing something that is already commercially available. There is a smaller likelihood that an unforeseen problem will arise because the vendor performs their own quality checks on their products.

5. Concept Selection

5.1 Structure Selection

After these rough designs were constructed, pros and cons were analyzed to select the superior design. For the S-1, the modular nature of the 80-20 makes it very easy to assemble and modify. Ordering is also easy and it takes very little machine shop time to fabricate. However, the $\frac{1}{4}$ - 20 hardware used to fasten the pieces together might not carry extreme stress and shear. In its basic form, the structure offers little protection for the waveguides from the elements or accidental bumps. Considering the weight of the support box from last project, it could deform the beams if the supports are not strong enough.

Structure S-2 also has its own advantages. The thicker cross section of Al used allows more rigidity to stress and strain. Additionally, larger bolts than $\frac{1}{4}$ -20 can be used in assembly which will give more strength and rigidity to the connections. There is also a larger surface area for ground or cart contact which will aid in stability. But, the size and complexity of the four L brackets will take a lot of time and money to assemble. This design is also substantially heavier than S-1 with the back mount control box can cause additional deformations.

In addition to these pros and cons, a Pugh decision matrix was constructed with the engineering characteristics to further guide us to the optimal solution. For this matrix, last year's design Generation 1 (Gen 1) was used as a baseline of 0 all around the board. A value of 2 was assigned for the design that offered a great improvement over Gen1 while a score of 1 was used for a slight improvement. Zero was assigned if there was not real improvement upon the original. The results can be seen below in Table 2.

Table 2: Decision Matrix, Structure Design Selection

Categories	Gen 1	S-1	S-2
Horn Accesability	0	2	0
Mounting Position	0	2	1
Locking Movement	0	0	2
Material Used	0	2	1
Base Dimensions	0	1	0
Cost to Produce	0	2	0
Total	0	9	4

In terms of accessing the horns for adjustment, S-1 excels because the waveguides extend out of the front of the structure and offer access from any angle. Gen1 and S-2 have the waveguide sandwiched between two pieces for limited access. In terms of mobility and mounting position, S-1 offers limitless opportunities and S-2 has a slot for changes much better than the solid holes of last year's design. S-1 also performs excellently for materials used and cost to produce since it's cheap and lightweight yet strong. It earns a nine over a four from the S-2 design, which in reality is mostly a copy from Gen1 just made with aluminum to be lightweight. From this Pugh matrix, Structure S-1 is the general format with which our team will go forward.

5.2 Horn Holder Analysis and Selection

5.2.1 Design H-1 Analysis

Pros:

Design H-1 offers a great deal of adjustability where it is needed most. The horn holder allows horizontal translation through its screw-to-clamps at the ends of the brackets. It also offers over 90 degrees of rotation on the axis between the brackets and rectangular brace. It also restricts some of the rotational range on the opposite axis between the brace and flange. This is ideal for the prospective column that each horn is mounted on, whether that is the horizontal or vertical column of the structure. Design H-1 also keeps its rotation about a center point with increases the ease of use and potential accuracy.

Cons:

Design H-1 offers a challenge is its control of adjustability. Because each rotation axis will be screwed in at two opposite ends, it will require both ends to be loosened to adjust, then both to be tightened to keep it in place. This can open up room for error in accuracy. Further fastening concept generation can improve this design.

5.2.2 Design H-2 Analysis

Pros:

Design H-2, is a very simple design because it is taken straight from a design that is already made and is in use for mounts for TV's, antennas, and computer monitors. Because it is similar to the designs of multiple mounts already being used, we know that the design already works and is effective.

Cons:

Design H-2 is easier to deal with on the horizontal column. If you refer to Figure 9, the 80/20 component slides into the 80/20 structure piece where a pin will tighten or loosen to either fix or enable translational movement for the antenna respectively. On the vertical component of the structure, this may pose as an issue because of how that 80/20 pivot nub is connected to the rod that keeps the antenna upright. This may also be an issue because the pivots are not on the centerline.

5.2.3 Horn Design Selection

While the team currently has not formerly proposed a final design for the horn holders to the sponsor, we believe the favorable design to be design H-1. Design H-1 has the superior structure compatibility because it can be mounted on the vertical or horizontal columns with equal ease. Design H-2 has an ideal horizontal mounting compatibility but lacks in the vertical mounting capability. Because Design H-1 mounts about to slots, its translation is easier and more stable. Whereas Design H-2 is mounted in one slot and will be less stable when translating. Design H-2 has superior rotational lock-ability over Design H-1 because it rotates about one pin on each axis. Design A extends very far from the frame structure and thus has a non-ideal size. Because of this size and off center axes, its ease of adjustability does not score as high as Design H-1.

Table 3: Decision Matrix, Horn Holder Designs

Attribute	Gen 1	Design H-1	Design H-2
Structure compatibility	0	2	1
Ease of translation	0	2	1
Lock-ability	1	1	2
Size	1	1	0
Ease of adjustability	0	2	1
Total	2	8	5

5.3 Base Selection

The selection for the base is not going to be determined at this time. The team has proposed multiple options and their possible benefits, but there is not enough information to make an informed decision. It is preferred to wait on creating detailed designs so that there are not multiple, unnecessary revisions to this aspect since it will be a trivial design.

6. Methodology

In order to ensure all parties are up to date and involved in the project process, we will have weekly team meetings, weekly sponsor meetings, and bi-weekly meetings with faculty. The project manager has been tasked with keeping documentation on the process so it can be referred to by the team later in the process, or by another interested party. To apply structure to the project, the following methods have been employed.

6.1 Work Breakdown Structure

In an effort to break down the project into more manageable parts, it has been partitioned in the following sections:

Table 4: Work Breakdown Structure

SAR Imager Redesign						
Initial Web Page Design	Conceptual Design	Midterm Report	Interim Design	Final Web Page	Final Design Poster	Final Design Report
<ul style="list-style-type: none"> -Create domain name -Gather all information and documents and deliverables -Create separate links for ME and ECE teams -Gather professional pictures for site -Place all items in their respective places on website 	<ul style="list-style-type: none"> -Know the current design, how it works and it's flaws -Brainstorm ways to fix the flaws in design -Come up with multiple designs, based off resources, costs, and calculations -Choose best design for both the horn and the structure 	<ul style="list-style-type: none"> -Combine all deliverables to be expressed in one documents -Show conceptual designs of structure, of horn, and of the whole device. 	<ul style="list-style-type: none"> -From conceptual design, edit and modify based off of calculations and testing -Make sure all steps are documented well 	<ul style="list-style-type: none"> -Continue to gather all information and documents and deliverables -Place all items in their respective places on website 	<ul style="list-style-type: none"> -Brief Synopsis of the project as a whole. -Include pictures and make sure that anything stated is easily understood. 	<ul style="list-style-type: none"> -Explain everything that has been done from the project. -Include pictures and take everything from previous documents and design and include them in the final report.

There are requirements placed on the team by both the course and the project. Meaning there are deliverables required to obtain grades to pass the course, and also there is an expectation by the sponsors that the project will be completed to a satisfactory level. The work breakdown structure

reflects the course requirements. For information on the project requirement breakdown, see Figure 12.

6.2 Schedule

In order to have a successful project, a clear plan must be laid out. Because there are so many steps in between starting the project and completing it, creating a rigid schedule for every task along the way is difficult. The following schedule has been proposed for the remainder of the fall semester, but allows for some room to change as needed.

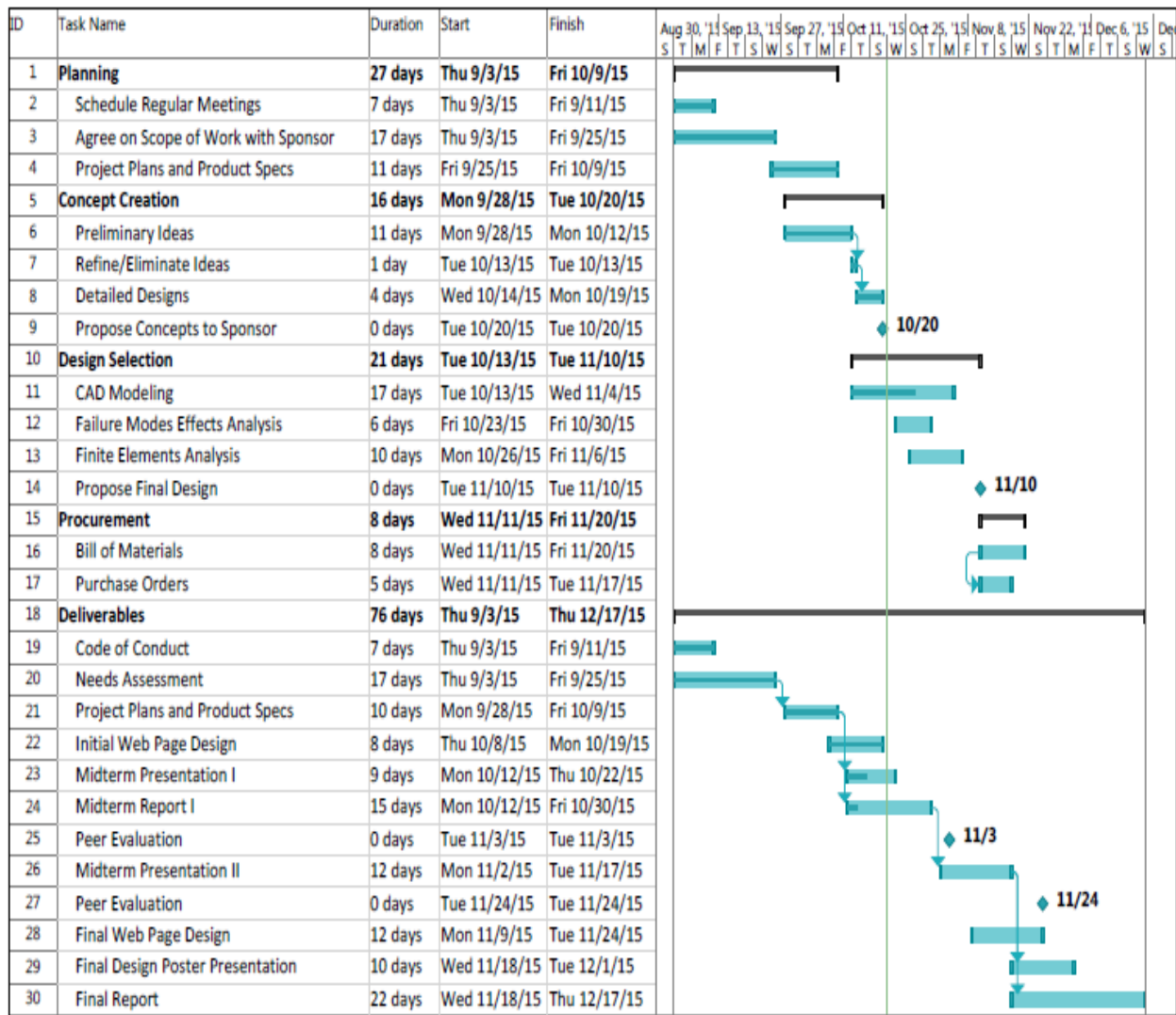

Figure 12: Gantt Chart for Fall Semester

6.3 Resource Allocation

In order to have a successful project, roles must be assigned and clearly defined for each member. While the group will strive to work cooperatively on all parts of the project, a member has been assigned leadership of specific aspects of each part of the project:

A. Josh Dennis - Team Leader

He is the person responsible for setting all meetings with sponsors, advisors, teachers, and ensures that the group is completing the project based off of what the sponsors are requesting and in an efficient manner. He also keeps track of all documents and ensures that each group member is doing their fair share.

B. Luke Baldwin – Structure Design

It is his responsibility to modify the existing structure by redesigning based off of the needs of sponsors, errors from the previous group, and constraints that are set.

C. Kaylen Nollie - Horn Holder Design

Kaylen has been placed in charge of designing a method to hold the antenna assemblies in a manner that meets all requirements of the operation of the SAR.

D. Desmond Pressey - Web Design, Budget

Has the duty of creating, editing, and translating all relevant information to the web page. Additionally, all purchasing will be handled by Desmond, including obtaining quotes from vendors and submitting purchase orders.

7. Risk Assessment

For the purpose of this report, all risks considered will be limited to safety-related risks. After analysis by the mechanical engineering team, the overall risk of the design was considered to be very low due to the following reasons:

- The structure must weigh under 80 lbs
- There will be no moving parts with high energy in the system
- Low voltages will be needed to operate the components
- The radar was designed to meet federal safety regulations
- The structure will be stationary unless manually relocated

While inspection yielded no major sources of risk, a detailed list of possible risks were outlined in Table 5.

Table 5: Risk Analysis

No.	Description of Risk	Possible Consequences	Prob.	Severity	Overall Risk	Plan
1	Electrical components are not properly housed	User is electrocuted	M	M	M	Ensure any component carrying electricity is properly insulated and cannot be accidentally touched.
2	Structural failure	Structure could fall on someone nearby	L	L	L	Because it is a low-weight design, proper construction should prevent this failure.
3	Hazardous edges, corners of structure	A sharp edge or corner could cut the operator	M	L	M	Any fabricated components edges' will be smoothed over. Protruding edges will be avoided in design.

8. Future Plans

8.1 General Overview

Because the time until the end of the fall semester is very short, the team is pushing very hard to get all designs completed as soon as possible. The plan will be to have all parts ordered before the end of the semester. The reason for this is because it is a clear, logical division between the design phase and the construction phase. The spring semester will be allotted for construction, prototyping, testing, and final adjustments. In order to be able to submit purchase orders by the beginning of December, all designs must be completed, a bill of materials created, quotes obtained, and purchase orders submitted.

8.2 Upcoming Deadlines

Based on the Gantt Chart seen in Figure 12, the remaining project deadlines are seen in Table 6.

Table 6: Remaining Fall Schedule

Design Selection

10/30/2015	Failure Modes Effects Analysis
11/4/2015	CAD Modeling
11/6/2015	Finite Elements Analysis
11/10/2015	Propose Final Design

Procurement

11/20/2015	Bill of Materials
11/27/2015	Purchase Orders

The remaining tasks provide the basis to be able to submit purchase orders by the end of the semester. The tentative date to submit purchase orders is November 27th, while the semester ends December 11th. This additional time was allotted at the end in case there are any delays due to unforeseen circumstances.

9. Conclusion

The first generation of the SAR project was an achievement in pathfinding, but left much to be desired. This year's mechanical engineering team has been tasked with making significant improvements to mechanical aspects of the project, including cutting weight, lowering cost, increasing stability, and allowing for a better method of horn adjustment.

The progress of this year's mechanical engineering team on the SAR Imager project is nearing the end of the design phase. There will undoubtedly be more revisions to the designs after conferring with the Northrop Grumman sponsors and getting input from the electrical engineers, whose design requirements are also changing throughout the life of the project. The team has many ideas for additional capabilities of the designs, but the implementation of these will be limited based on the operational ability of the electrical components, the budget, and the time frame left to complete the design phase.

In all three aspects of the design: structure, horn holders, and base, the integration of 80/20 product is being favored because the exact requirements of the project have already changed multiple times throughout the designing of these components. Additionally, a negative part of the design from last year is that there are few reusable components for the structure this year. At this moment, the team believes this project will be continued into a third generation next year. The 80/20 lends itself very well to being able to be modified on-the-fly as needed. This will give next year's team a platform to modify as needed. The other advantage of 80/20 is that the vendor already has a catalog of hundreds of components that choose from. This cuts down on design time, fabrication costs, and unforeseen problems arising.

The immediate order of business will be to submit all designs for review to the sponsors and electrical team. Based on current progress, the team feels confident that they can meet all deadlines and be ready to submit purchase orders before the end of the semester.

References

1. Business Sectors. *Northrop Grumman*. [Online]
<http://www.northropgrumman.com/AboutUs/BusinessSectors/Pages/default.aspx>.
2. Northrop Grumman. *WikiMedia*. [Online]
https://upload.wikimedia.org/wikipedia/commons/4/47/B-2_Spirit_original.jpgicles, Ph.D.
dissertation, Florida State University, Tallahassee, FL, June 2014..
3. Kremer, Kem. James Webb Space Telescope's Giant Sunshield Test Unit Unfurled First Time. *Universe Today*. 2014.
4. Cooper, Helene. Northrop Grumman Wins \$21.4 Billion Pentagon Contract. *The New York Times*. 2015.
5. Radar Tutorial. [Online] http://www.radartutorial.eu/20.airborne/pic/sar_principle.print.png.
6. Synthetic Aperture Radar. *Lockheed Martin*. [Online]
<http://www.lockheedmartin.com/us/products/sar.html>.
7. Synthetic Aperture Radar. *Radar Basics*. [Online]
<http://www.radartutorial.eu/20.airborne/ab07.en.html>.
8. Cammuse, Matthew. Final Presentation. *SAR Imager Home*. [Online]
http://eng.fsu.edu/me/senior_design/2015/team27/Webpage/presentations/Team%20E%2311_Milestone%20%237%20Presentation_%20Final%20Report.pptx.
9. Final Report. *SAR Imager Home*. [Online] http://eng.fsu.edu/me/senior_design/2015/team27/.
10. Platform Trucks. *McMaster-Carr*. [Online] <http://www.mcmaster.com/#carts/=zgsvoa>.

Appendix

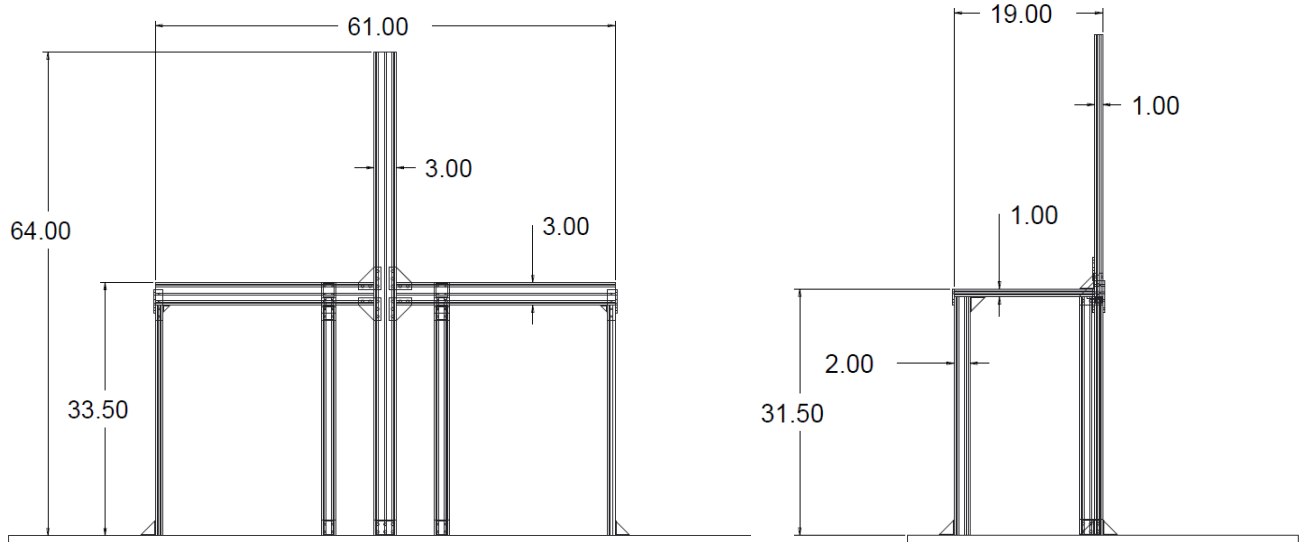

Appendix A: Detailed drawings of design S-1

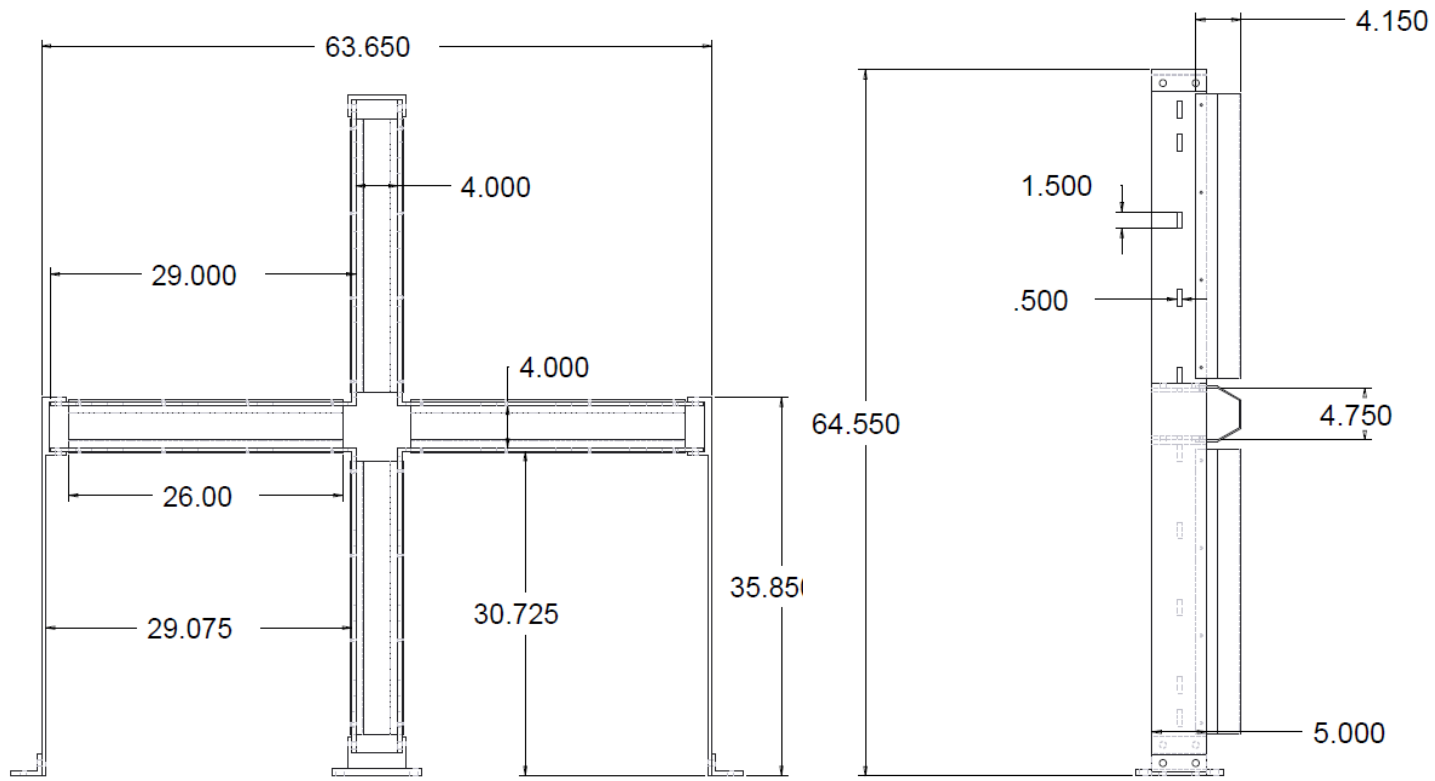

Appendix B: Detailed drawings of design S-2

Biography

Luke Baldwin, Structure Designer:

Luke Baldwin is a senior in the Mechanical Engineering department pursuing a speciality in Aerospace Engineering. He is working part time as a Research Assistant at the Florida Center for Advanced Aero Propulsion learning about the experimental techniques of PIV and Shadowgraphy.

Josh Dennis, Project Manager:

Josh is a Mechanical Engineering major with a concentration in Material Science. Josh will graduate in April 2016 with his Bachelors of Science degree. He is currently employed at an engineering firm in town working on industrial plant design and construction management. His significant contributions include developing proprietary programs that assist in automating database management.

Kaylen Nollie, Antenna Designer:

Kaylen Nollie is a Mechanical Engineering student from Richmond, VA. She has previously worked as a mentor to incoming Engineering students as well as tutored in Calculus I, Calculus II, Calculus III, Physics I, and Physics II for the College of Engineering. She is also a Naval ROTC student who is graduating and commissioning as a Naval Officer in Spring 2016.

Desmond Pressey, Financial Advisor and Website Administrator:

Desmond Pressey is a senior Mechanical Engineering major from Orlando, FL, enrolled at Florida A&M University. Desmond is currently involved with a number of clubs and organizations including, NSBE, Theta Tau Engineering Fraternity, and is the president of the Society of Engineering Entrepreneurs. He is also a mentor for pre-engineering students.